



Vacuum Pump Protection Filters

Models | A006 to A300

Flow Rates 4 SCFM (7 Nm³/hr) to 288 SCFM (489 Nm³/hr)

Essential for the removal of liquid and particulate contamination, Walker Filtration's New Alpha Vacuum Pump Protection Filters offer a high efficiency solution for both rough and high vacuum applications.

Offered in a range of 15 models with threaded connections from 3/8" to 3", the New Alpha high efficiency filters prevent process contamination from entering liquid or dry running vacuum pumps - helping to prevent damage to rotating parts and costly downtime.

The New Alpha elements utilise custom engineered media technology to deliver market leading performance, significantly reducing pressure loss and energy consumption for low operational costs and increased performance. The VLR grade is used for liquid aerosol and high dirt removal, whilst the VX1 grade is used for fine particulate removal.



Assured Protection

Highly efficient removal of solid particles and other contaminants ensure prevention of damage to the Vacuum Pump



Optimised Filtration Performance

New Alpha custom engineered media technology delivers a step change in performance



Product Safety in Mind

Lock indication arrows assure effective sealing

- **Market Leading Performance** Custom engineered filtration media delivers optimum performance
- **Simplified Serviceability** Profiled bowl design and unique push fit filter elements ensure quick and reliable maintenance
- **Exceptional Drainage** Manual drain fitted to all Vacuum Pump Protection Filters as standard
- **Product Safety in Mind** Guaranteed safe housing closure with rotational safety stop
- **Corrosion Protection** Internal and external electrophoretic paint finish followed by a tough exterior polyester powder coating



Technical Specification

Filter model	Pipe size inches	Exhaust flow rate (vacuum displacement)		Dimensions mm				Weight Kg	Element model
		Nm ³ /hr	SCFM	A	B	C	D		
A006 (grade)	3/8	7	4	70	24	231	70	0.6	EW006 (grade)
A010 (grade)	1/2	11	7	70	24	231	70	0.6	EW010 (grade)
A014 (grade)	1/2	20	12	127	32	285	80	1.7	EW017 (grade)
A017 (grade)	3/4	25	15	127	32	285	80	1.7	EW017 (grade)
A021 (grade)	1	29	17	127	32	285	80	1.7	EW017 (grade)
A025 (grade)	3/4	35	21	127	32	371	80	2	EW035 (grade)
A035 (grade)	1	50	29	127	32	371	80	2	EW035 (grade)
A056 (grade)	1 1/4	75	44	170	53	508	100	4.9	EW090 (grade)
A080 (grade)	1 1/2	100	59	170	53	508	100	4.9	EW090 (grade)
A090 (grade)	2	115	68	170	53	508	100	4.9	EW090 (grade)
A140 (grade)	2	180	106	170	53	708	100	5.5	EW140 (grade)
A170 (grade)	2 1/2	200	118	220	70	736	100	10.5	EW180 (grade)
A180 (grade)	3	234	138	220	70	736	100	10.5	EW180 (grade)
A250 (grade)	3	360	212	220	70	857	100	11.5	EW250 (grade)
A300 (grade)	3	489	288	220	70	1005	100	12.5	EW300 (grade)

Rated flow at atmospheric pressure, 1 bar (a) and 20°C

Grade	VLR		VX1	
Particle removal	5 micron		1 micron	
Maximum temperature	120°C	248°F	120°C	248°F
Pressure loss - clean & dry	20 mbar	0.3 psi	40 mbar	0.6 psi
Pressure loss - element change	12 mths	8000 hrs	12 mths	8000 hrs
Maximum working pressure	20.7 barg	300 psig	20.7 barg	300 psig
Maximum working vacuum	Full vacuum		Full vacuum	
Element end cap colour	Green		Red	

Vacuum Correction Factors		For maximum flow rate, multiply model flow rate by the correction factor corresponding to the minimum operating pressure									
Operating vacuum	Mbar abs	Atmospheric	900	800	700	600	500	400	300	200	
	Torr	760	675	600	525	450	375	300	225	150	
	InchHg	29.9	26.6	23.6	20.7	17.7	14.8	11.8	8.9	5.9	
	Psia	14.7	13.0	11.6	10.2	8.7	7.3	5.8	3.3	2.9	
Correction factor		1.00	0.93	0.86	0.79	0.71	0.64	0.57	0.5	0.43	

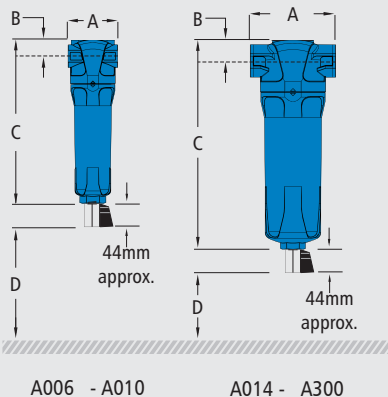

Technical notes

- Direction of air flow is inside to out through VLR grade and outside to in through VX1 grade.
- Pop up indicators (65DPUGA3-100) are fitted to models A006 to A010. Differential pressure gauges (65DPG250G) are fitted to models A014 to A300 as standard. Volt free contact options are available upon request - see price guide.
- Manual drain valves (MDV25 on models A006 to A010 and MDVE25 on models A014 to A300) are fitted as standard.
- Drain flasks are available for liquid collection for use at atmospheric pressure or vacuum only.
- New Alpha Filters are manufactured from cast aluminium alloy and are PED 2014/68/EU compliant for group 2 gases.
- Threaded connections are Rp (BSP Parallel) to ISO 7-1 or NPT to ANSI/ASME B1.20.1 if supplied within North America. Rc (BSP Taper) to ISO 7-1 also available.
- For NPT threads, add the suffix N, e.g., A014NVLR, and for Rc threads add the suffix C, e.g. A014CVLR.
- Filter elements should be changed every 12 months / 8000 hours (whichever comes first).



THE QUEEN'S AWARDS
FOR ENTERPRISE:
INNOVATION
2016